



megh neel

Megh Neel Renewable Power Systems Private Limited

Regd Office: 2/19, Elite Avenue, Near Sivaram Nagar,
Ganapathy, Coimbatore, Tamil Nadu, India - 641006

Email: sales@meghneel.co.in Web: www.meghneel.co.in

Phone: +91-422-2510165 Mobile: +91-98410 79631 (Navin), +91-7708066207 (Sales)

TIN: 33262227117 CST: 1098700 dated 12/5/13

Megh Neel – The Company

Megh Neel started its journey with a vision to develop and manufacture energy efficient devices and clean technology systems. Since inception, we have spent more than four years in research and development activities and have in-depth knowledge in construction of Brushless Direct Current Motors (BLDC), Permanent Magnet Alternators (PMA) and its applications including electric vehicles and home appliances. We currently are manufacturing BLDC Motors including controllers and PMAs. We are also providing consultancy services to leading companies in developing custom BLDC motors.

BLDC Motors

We are offering three series of BLDC motors comprising of inner rotor and outer rotor type ranging from 35 watts to 4 Kilowatts. Our BLDC motors uses high speed ball bearings with housing made either of aluminum (for light weight applications) or steel for heavy duty applications. The controllers for these motors come in either integrated or in separate housings. Both the series uses hall sensor based commutation.

Permanent Magnet Alternators

We are also offering PMAs for low wind speed turbines with direct drive mechanism. These PMAs output ranges from 1Kw to 4Kilowatts and can be customized for different operating speeds and output voltages.

Contact Information

Regd Office:

Megh Neel Renewable Power Systems Private Limited,
2/19, Elite Avenue,
Near Shivaram Nagar, Ganapathy,
Coimbatore – 641006

Mobile: +91-98410 79631 (Navin), +91-7708066207 (Sales)

Land Line: +91-422-2565413

Email: sales@meghneel.co.in

Web: www.meghneel.co.in

Intellectual Property Rights

The information shared in this document is protected by Intellectual Property Rights and the receiving party shall refrain from disclosing, reproducing, summarizing and/or distributing Confidential Information and confidential materials obtained either directly or indirectly, in writing, orally, by inspection of tangible objects (including, without limitation, documents, prototypes, samples, media, documentation, discs and code).



megh neer

OR120 Series – e-Bicycle Motors

Features

- ❖ Made in India
- ❖ Internal Planetary Gear with Ratio of 1:5
- ❖ Available with Ingress Protection 55
- ❖ High speed ball bearings used in the construction
- ❖ Aluminum housing for light weight applications

Applications

- ❖ Electric Bicycles
- ❖ Agricultural Automation
- ❖ Robotics
- ❖ Industrial Applications

We offer e-bicycle motors with outputs ranging from 250 Watts to 500 Watts. The motor features very low cogging, high torque and uses high quality copper wire windings for longer service life.



Technical Specifications

Parameter	Model - EBC-D180C-M1		
Construction Type	Direct Drive Hub with Internal Planetary Gear & one way clutch		
Rated Voltage	36V	36V	48V
Rated RPM	300 RPM	300 RPM	300 RPM
Rated Current (A)	7 A	10 A	10.5
Max Power (W)	250 Watts (Max)	360 Watts	500 Watts
Rated Torque (Nm)	8 Nm	10 Nm	15 Nm
Brake	Disc Brake PCD 48mm M5-0.8 x 8 Nos		
Installation Width	135 mm		
Hub Diameter	180 mm		
Spoke Specification	36H x 12G		
Cable	Through Shaft (Right Side)		
Finish	Black Powder Coated / Chrome		

Megh Neel e-Bicycle Motor

Model: EBC-D180C-M1

Disc Brake Mounting
PCD 48
M5 - 0.8 x 8 Nos

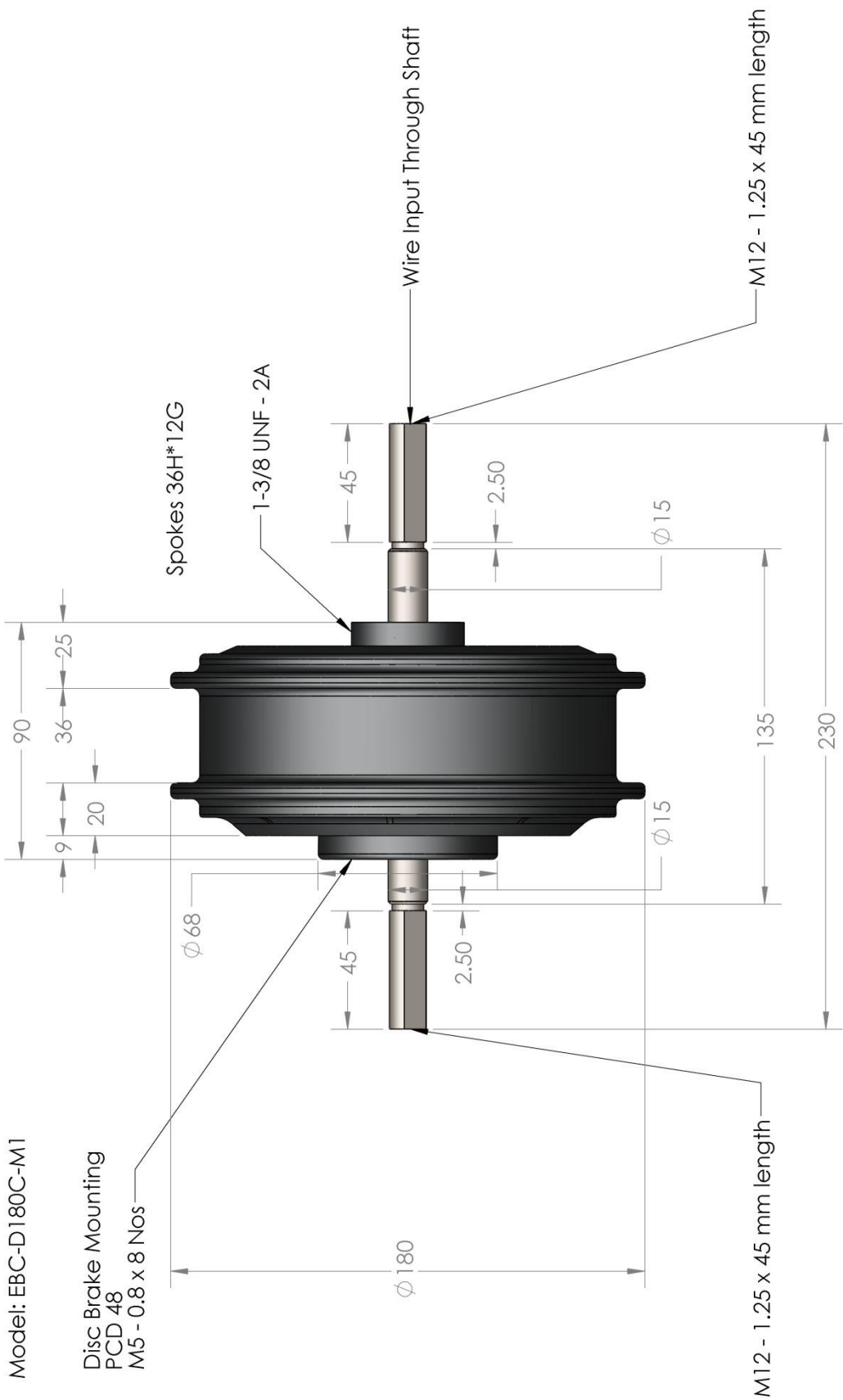

Rating: 250W, 300RPM, 1.5 Ratio

Suitable for 26, 27.5, 28 inch wheel sizes

(C) 2016 Megh Neel Renewable Power Systems Pvt Ltd